

Pile Turner for Logistic Systems

Model SWH 125 RLA (200) - Logistics

- Transferring paper piles onto system pallets
- Airing, jogging and aligning the paper pile
- Central positioning of the paper pile on the system pallet

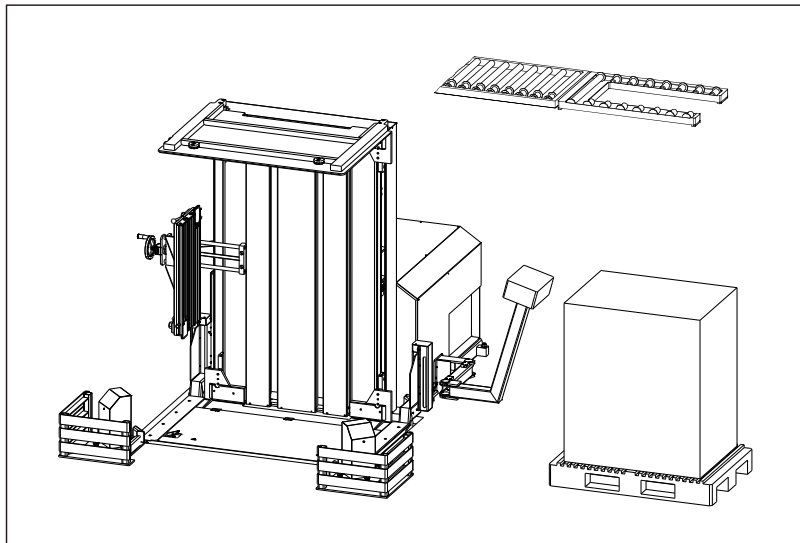

Performance

- The pile turner enables a throughput of up to 10 piles per hour
- The flexible use of the PLC offers a maximum of different operating sequences

Examples:

8 - 10 piles per hour for an exchange of pallets for piles supplied in turned position

6 - 8 piles per hour for an exchange of pallets by double turning

Technical Data

Platform width	mm	1370
Platform depth	mm	925
Max. pile height	mm	2000
Min. pile height	mm	810
Carrying power	kg	1200

Equipment

- Airing equipment with two 3 kW blowers and two air jets
- Airing position in 15° tilted position of the turning unit
- Electrical air volume regulation at the control desk
- Vibrating unit for jogging the paper pile in 15° tilted position
- Platforms with pressure control flaps (pile is not compressed - air cushion is preserved). Controlled compression of the pile is possible
- Aligning gauge with spring stop ends
- Loading from the narrow / wide sides
- Danger zone on the narrow and wide side is secured by safety light barriers

Different Versions

Version E

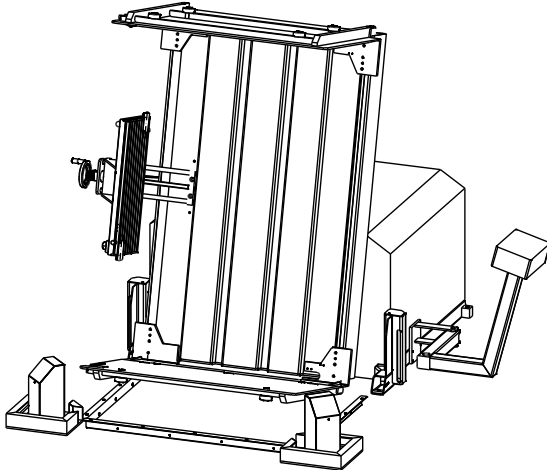

Pile Turner without ramps, access at ground level

Entry from the front side or from the right / left side (depending on the position of the aligning gauge).

- Access at ground level.
- A rectangular pit (depth of 80 mm) is necessary.
- The pile turner is fixed to the floor with dowels.

Version F

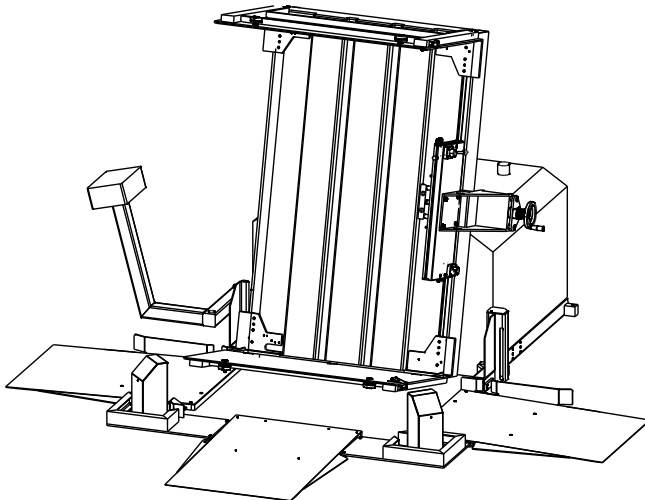

Pile Turner with ramps

Entry from the front side or from the right / left side (depending on the position of the aligning gauge).

- Access over ramps (length: 120 cm) onto platforms (height: 50 mm).
- Floor preparation is not necessary.
- The pile turner is fixed to the floor with dowels.